

High Pressure Cold Water Jet Machine

Operating Manual

Model: SKY2150CEM

Series: Monster

Pressure: 500 Bar

Flow: 21 Lpm



SKY TECH

AND CLEANING SYSTEMS PVT.LTD.

Touching New Horizon



+91 96192 68086

sales@skyengg.in

www.skytechcleaning.com

 Unit No. 1, Behind Reliable Tech Park, Gavate Compound, Airoli (E), Navi Mumbai 400708

1. INTRODUCTION

The horizontal Plunger Pumps are designed and manufactured to pump or transfer **water**. They are generally driven by: electric motors, endothermic petrol or diesel engines and hydraulic motors, tractor P.T.O... Couplings may be fulfilled by means of transmission shaft, direct flanging, reduction unit or multiplier, joints, pulleys and belts.

The Pumps are supplied standard with the power take-off of the shaft on the right, looking at the Pump from the head (see fig.1). On request, all Pump models can be supplied with power take-off on the left.



The Pump is supplied to be installed on a more complex machine or plant; the manufacturer of such machine or plant shall add all the information related to safety of the assembled machine/plant fulfilled.

2. INTENDED USE

Plunger Pumps are designed to be used in machines or systems for transferring pressurized water, such as the following for example: Car Wash, Civil and Industrial Washing Systems, Road Washers and Bin Washers, Water Treatment, Misting, Drain and Pipe Cleaning and Fire-fighting.

The temperature of the workplace shall be between: Min. 0°C (32°F) - Max. 45°C (113°F)

The Pump cannot be used submerged under any type of liquid.

3. OPERATIONAL RESTRICTION

The specifications of the liquid to be used are described in detail herewith: do not use for different liquids; in particular, it is NOT possible to use Pumps in the following conditions:



- In the presence of water with high salt content, such as seawater for example; for this type of use, you are recommended to use Pump stainless steel series.
- In workplaces where there is a corrosive or explosive atmosphere.
- In the presence of any liquid that is not compatible with the constructional material of the Pump.
- To pump paint, solvents, fuel and any flammable liquid (not suitable for ATEX workplaces).
- To foodstuffs.
- To wash people, animals, live electrical or electronic equipment.
- To wash the Pump itself.

4. GENERAL WARNING



- Never start the Pump under pressure.
- Constantly check the state of wear of the pipes and relevant fittings, especially those under pressure. Pipes with signs of abrasion or that do not guarantee a perfect seal shall be replaced.
- The Pump must never run dry/without any liquid while in use.



- Protect rotating parts with a cover to prevent contact..
- The Pump is designed to be integrated in a machine or system, with various supply systems, which may make the noise level vary, even quite substantially. The manufacturer of such machine or system shall assess the level of noise emitted by the assembled machine or system and inform the user appropriately, also in relation to the use of suitable personal Protection equipment.

5. BEFORE START UP

LIQUIDS TO BE PUMPED

The Pump is designed and manufactured to transfer clean liquid or non-aggressive watery solutions.

The liquid in taken must be free from sand or other solid particles in suspension.

The liquid in taken shall have viscosity and density similar to water.

The maximum temperature of the liquid to be pumped varies according to the conditions of the system (see section 6.3 - INLET CONDITIONS).

Any other use is not admitted unless authorized in writing by the Engineering Department of **SKY**.

INLET AND OUTLET OF THE PUMP

The Inlet port for the liquid that must be pumped is generally located on the lower part of the Pump's

head and may also be called the suction port or supply port. The Outlet port for the pumped liquid is generally located on the upper part of the head and may also be called the delivery port. The Inlet and outlet ports may be used either on the right or the left side of the Pump's head, by dismantling or inverting the closure plugs.

 The Inlet and Outlet CANNOT be inverted.

INLET CONDITIONS (SUCTION)

Pump is mounted above the supply tank.	Pump is mounted below the supply tank in gravity feeding.	Pump is pressure fed.
Max. difference of level between Pump and supply tank: 0,5 m/1.6 ft.	Max. Pump speed: 1750 RPM.	Max. Inlet pressure: 6 bar (90 PSI).
Max. working pressure: 500 bar (7250 PSI).	Max. inlet water temperature up to 500 Bar (7250 PSI) of Working pressure: 50°C (122°F).	The feeding source must provide 50% more than the Pump flow.
Max inlet vacuum: -0.2 bar (-6 inch.Hg).		If a pressure feeding Pump is used, it must be started before the plunger Pump.
Max. Pump speed: 1450 RPM.	Max. Inlet water temperature over to 500 bar (7250 PSI) of working pressure: 35°C (95°F).	Max. Inlet water temperature: 50°C (122°F).
Max. Inlet water temperature: 40°C (104°F).		
<p>The inlet pipeline must comply with the following requirements:</p> <ul style="list-style-type: none"> - Any point of the inlet pipeline cannot be smaller than the diameter of the Pump inlet. - Be absolutely leak-proof to avoid any air infiltration - Not have 90° bends near the Pump inlet. - Not have contractions or restrictions. - Avoid any turbulence near the Pump inlet and in the supply tank. - If an inlet filter is used, it must allow 200% more flow than the flow required by the Pump. It must not cause any contraction or any pressure drop. The filter should be grant a filtration degree between 50 and 80 meshes and should be cleaned on a regular basis to ensure its proper functionality. 		

Any other use is not admitted unless authorized in writing by the Engineering Department of SKY.

OUTLET CONDITIONS

Make sure the delivery line and all the accessories are connected correctly, secured firmly, hermetically sealed and that the pipes are sized appropriately. All pressurized pipes must be marked durably with the maximum admitted pressure, which must never be less than the maximum working pressure of the Pump, written on the Label

SPEED AND ROTATION DIRECTION

 The rotation speed of the shaft of the Pump must never exceed the RPM written on the Label of the actual Pump.

The minimum RPM admitted is: maximum RPM x 0.6.
The rotation direction of the shaft of Pumps may be clockwise or anticlockwise.

6. CONTROLS ON SYSTEM

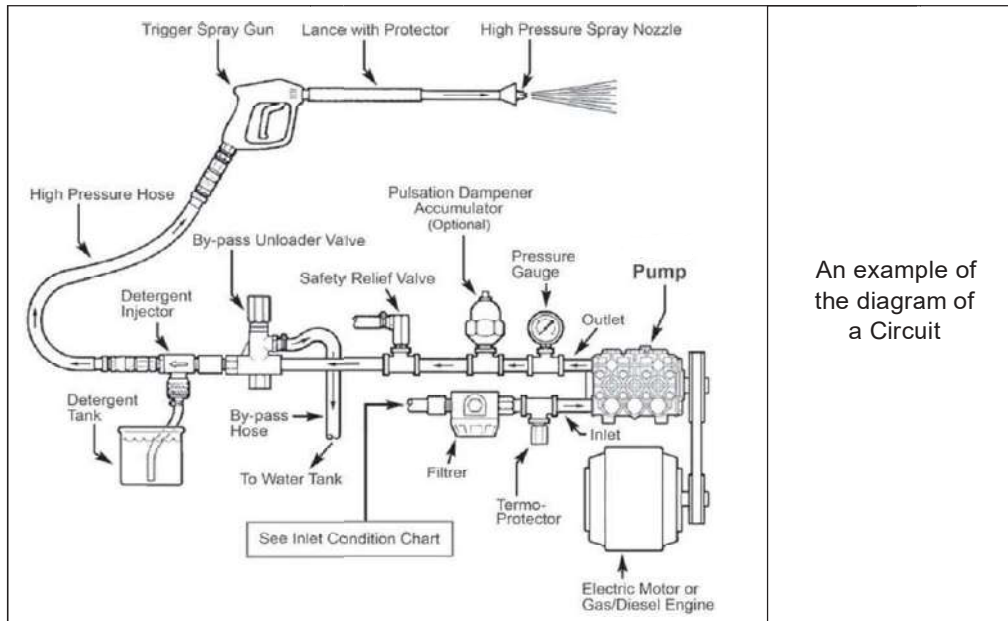

UNLOADER VALVE

A pressure regulator valve must be installed to avoid the pressure exceeding the maximum limit indicated on the Label of the Pump.

 Use of the Pump, even for a short period, with a pressure higher than such limit would damage the Pump itself.

The regulator valve shall be compatible with the maximum pressure, flow rate and temperature values written on the Label and in the "INLET CONDITIONS".

 Incorrect installation of the pressure regulator valve could cause serious personal injuries and damage to property as well as seriously damaging the actual Pump.

The circuit must be equipped with another safety valve to prevent the maximum pressure from being exceeded in the case of anomalies in the pressure regulator valve.

NOZZLE

A deteriorated nozzle could cause a drop in pressure; in this case, do not adjust the pressure regulator valve in the attempt to increase the pressure of the system because when the delivery line closes, this would cause a boost in pressure, which could damage the Pump.

If the pressure drops, it is advisable to replace the nozzle and adjust the system's pressure again. The flow rate of the Pump must be at least 10% higher than the flow rate that the utilities demand; the excess flow rate must be discharged.

PULSATION DAMPENER (ACCUMULATOR)

For applications in which pulses produced by the Pump on the delivery line are harmful or undesired, install an appropriately sized pulse dampener.

PRESSURE GAUGE

Install a gauge as near as possible to the outlet of the Pump because the maximum pressure written on the Pump's Label refers to the pressure detected on the head of the Pump and not on the nozzle or on other accessories.

 All the components of the machine or of the circuit must have technical specifications compatible

with the data written on the Pump's Label.

7. INSTALLATION, START UP AND SWITCHING OFF

POSITIONING

Smaller and lighter Pumps can be handled by hand in compliance with current standards. Heavier Pumps must be handled using the dedicated hook and suitable lifting device. If there is no eyelet and you need to use a lifting device, use appropriate strap/s, being careful not to damage the product. The weight of the Pumps is written in the table on page 25.

If the Pump is used in particularly dirty workplaces or is exposed to atmospheric agents, you are recommended to protect it, respecting the ventilation conditions.

ASSEMBLY

Fit the Pump on a rigid surface keeping the power take-off and support feet horizontal to ensure correct drainage in the case of leakage of water or oil. The Pump must be secured firmly on a base, which must be perfectly aligned with the transmission components. In the case of belt transmission, make sure the pulleys are aligned and check the tension of the belts.

Use appropriately sized hoses, both on the inlet and outlet of the Pump, according to the technical specifications written on the Label.

START UP

Before starting, check the following:



Replace the RED cap on the Pump Crankcase with the venting cap in the kit of accessories supplied.

- Check the oil level through the dedicated oil reservoir or inspection cap; top-up if necessary.
- Check the pressure value on the accumulator, if installed; inflate or deflate if necessary.
- The pressure regulator valve must be set at "0" pressure to favour intake.

Start and run the Pump for approximately 10 seconds until all the liquid has discharged from the delivery line. Once the intake cycle is complete, you can set the Pump at the required pressure, by adjusting the pressure regulator valve, without ever exceeding the maximum pressure written on the Pump's Label.

SWITCHING OFF AND STORAGE

After use or if the Pump is to be put away in storage, wash it internally. You can do this by running the Pump for several minutes with clean water, then disconnect the supply line and leave the Pump to run for approximately 15 seconds so that all the water in the head is discharged.

A few minutes devoted to the internal washing of the pump brings considerable benefits in terms of the pump's lifetime.



Do not wash the Pump externally: water could get into the Pump crankcase, for example through the oil vent cap.



After switching off, the Pump could remain very hot for some time.



Do not throw the liquid used to wash the Pump outdoors but observe current standards.

PRECAUTIONS AGAINST FREEZING

If shutdown during winter or in the case of places and seasons subject to frost, once the Pump has finished working, run it for the time required to pump an emulsion of 50% of clean water and 50% of antifreeze fluid through it in order to prevent freezing and damage to the Pump.

The Pump must not be used to Pump antifreeze fluid that is not mixed with water.

In the presence of ice or very cold temperatures at the workplace, the Pump must never be started; otherwise the Pump could be seriously damaged. To start the system, the whole circuit must be completely defrosted.

8. MAINTENANCE

ROUTINE MAINTENANCE

If the Pump is used for light-duty purposes, the following routine maintenance jobs are advised:

- After the first 50 hours: Oil change (see section 9.2 - Lubrication)
- Every 200 - 300 hours: Oil change (see section 9.2 - Lubrication)
- Every 1000 hours: Replace the valves - replace piston seal rings for heavy-duty purposes, carry out the maintenance jobs more often.



When inspecting or replacing the Pump valves, be careful which type of Loctite® you use on the caps over the valves (see table on page 26-27).

LUBRICATION

The Pump is supplied with the correct amount of lubrication oil (see table on page 25). Periodically check the oil level in the Pump through the oil level indicator.

Use OIL type SAE 15W-40 or equivalent. Here are some recommended types of oil:

BRAND	TYPE
AGIP	F.1 Supermotoroil 20W-40
BP	Vanellus C 20W-40
CASTROL	GTX 20W-40
ESSO	Uniflo 20W-40
MOBIL	Super M 20W-40
SHELL	Rimula R4 20W-40 / Helix Super 20W40
TOTAL	Rubia 20W-40 / Quartz 5000 20W-40

The oil is to be changed by draining it through the dedicated bottom oil drain plug and strictly with the Pump stopped.

Every time you unscrew the oil drain plug we suggest replacing its gasket



DO NOT START THE PUMP IF THERE IS NO OIL IN THE PUMP!



During maintenance, you are recommended to:

- Use and wear suitable personal protection equipment (i.e. gloves). Wait for the machine to cool down and to have stopped completely.



During maintenance, do not throw residues outdoors but observe current standards.



If the Pump is to be scrapped:

1. Separate the various parts depending on their type (i.e. plastic, harmful fluids, metal etc.).
2. Use public or private waste disposal systems envisaged by local law to dispose of waste.
3. This device could contain harmful substances: improper use or incorrect disposal could have negative effects on human health and on the environment.

9. TROUBLE SHOOTING

PROBLEMS	PROBABLE CAUSES	SOLUTIONS
The Pump doesn't reach required pressure.	Incorrect or worn or plugged nozzle.	Change to proper size nozzle; replace nozzle or clean nozzle.
	Belt slippage.	Tighten or replace belt.
	Air leak in inlet plumbing.	Check or replace hoses or fittings.
	Inlet suction strainer clogged or improper size.	Check and clean, use adequate size.
	Worn seals. Abrasives in Pumped fluid; severe cavitations; inadequate water supply.	Install and maintain proper filter. Replace seals. Check inlet supply: Max. -0,2 bar (-6 inch.Hg) vacuum.
	Pressure gauge is broken or not registering accurately.	Check with new gauge; replace worn or damaged gauge.
	Relief / unloader valve stuck, partially plugged or improperly adjusted.	Adjust or repair or replace relief / unloader valve.
	Dirty or worn inlet or outlet valves.	Check and clean or replace valves.
	Leaky outlet hose.	Check or replace discharge hoses or fittings.
Pump is noisy.	Air leak in inlet plumbing.	Check or replace hoses or fittings.
	Inlet strainer clogged or improper size or insufficient supply of water to the Pump.	Check and clean, use adequate size; increase water supply if not sufficient.
	Dirty or worn inlet or outlet valves.	Check and clean or replace valves.
	Worn seals or o-rings.	Replace seals or o-rings.
	Plugged inlet filter or improper size.	Clean or replace filter.
	Pulley loose on crankshaft or worn key.	Check pulleys and key.
	Broken or worn bearings.	Replace bearings.
Water leakage under the Pump head.	Worn low pressure seal or o-ring.	Replace seal or o-ring.
	Cracked plunger.	Install new plunger.
Water in crankcase. Oil is changing color into white.	High humidity in air (condensing).	Change oil every 250 hours instead of 500.
	Worn crankcase oil seal.	Replace crankcase oil seal.
	Worn low pressure seal.	Replace seal.
Oil leak between crankcase and head.	Worn crankcase oil seal.	Check plunger rod. Replace crankcase oil seal.
Oil leak in the area of crankshaft.	Worn crankshaft oil seal.	Replace crankshaft oil seal.
	Worn bearing case o-ring.	Replace bearing case o-ring.
	Bad bearings.	Replace bearings.
Oil leak at the reared of the Pump.	Damaged or improperly installed sight glass or crankcase cover seal or drain plug.	Replace sight glass, plug or seals.
Frequent or premature failure of the packing.	Scored plungers.	Replace plungers.
	Over pressure in inlet manifold.	Reduce inlet pressure.
	Abrasive material in the fluid being Pumped.	Install proper filter on Pump inlet plumbing.
	Corrosive additives in the fluid being Pumped.	Use clean water or contact SKY Technical Service Department for more information's.
	Excessive temperature of fluid being Pumped.	Assure fluid inlet temperature are within specified range (see page 20).
	Running Pump dry.	Do not run Pump without fluid.
Excessive vibrations in outlet line.	Air leak in inlet plumbing.	Check or replace hoses or fittings.
	Pulsation damper pressure too low.	Check and repressure.
	Dirty or worn inlet or outlet valves.	Check and clean or replace valves.

XM-1

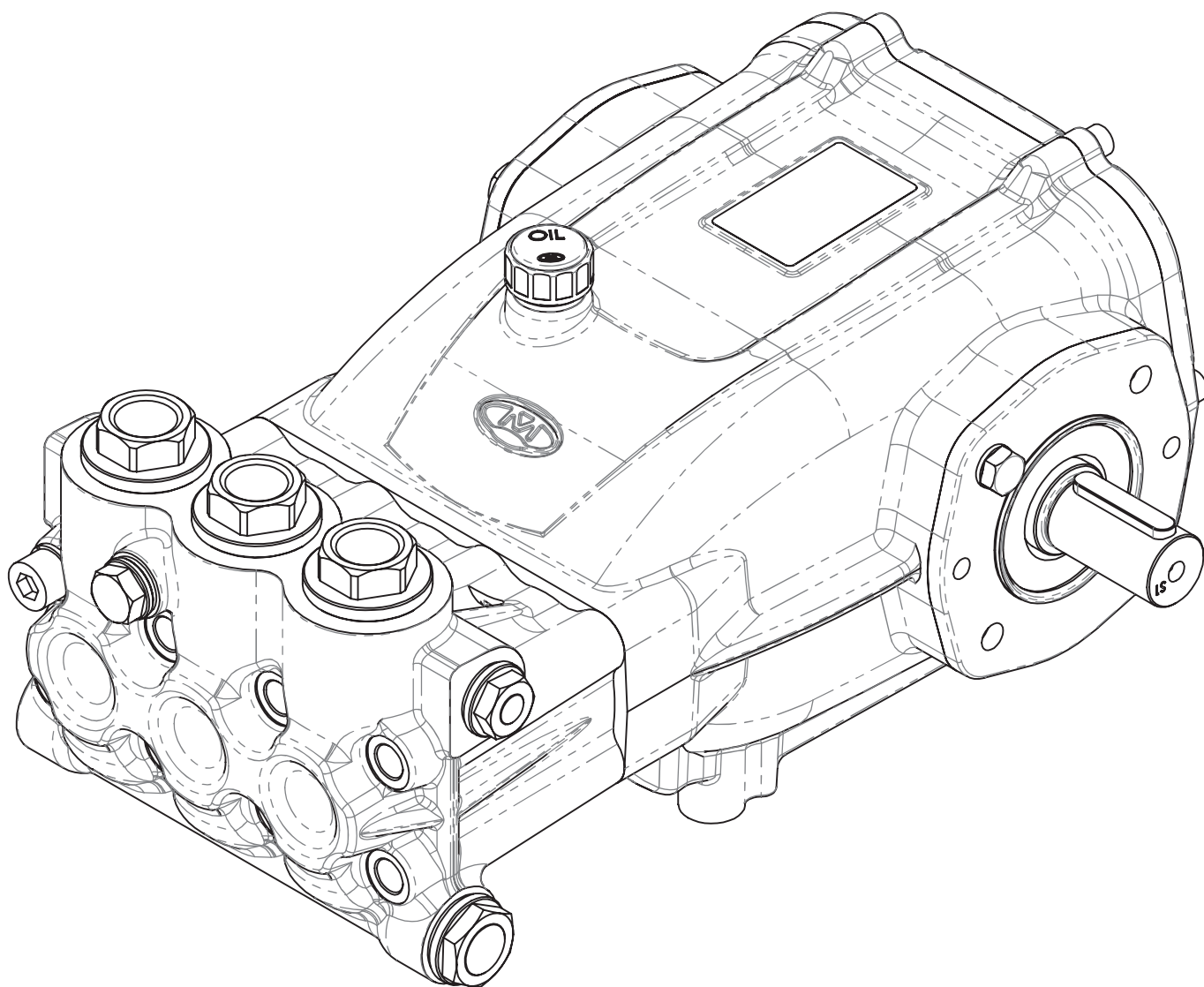

General table

Model	Pressure (Bar)	Pressure (Psi)	Flow Rate 1450 rpm (Lit/min)	Flow Rate 1740 rpm (Lit/min)	Flow Rate 1450 rpm (gpm)	Flow Rate 1740 rpm (gpm)	Round 50Hz (RPM)	Round 60Hz (RPM)	Power 50Hz (Hp)	Power 50Hz (Kw)	Power 60Hz (Hp)	Power 60Hz (Kw)
XM11500 (R-L)	500	7251.89	11.00	13.20	2.91	3.49	1450	1740	14.29	10.58	17.14	12.70
XM15500 (R-L)	500	7251.89	15.00	18.00	3.96	4.76	1450	1740	19.48	14.43	23.38	17.32
XM17500 (R-L)	500	7251.89	17.00	20.40	4.49	5.39	1450	1740	22.08	16.35	26.49	19.62
XM21500 (R-L)	500	7251.89	21.00	25.20	5.55	6.66	1450	1740	27.27	20.20	32.73	24.24

Exploded XM-1

Esploso XM-1

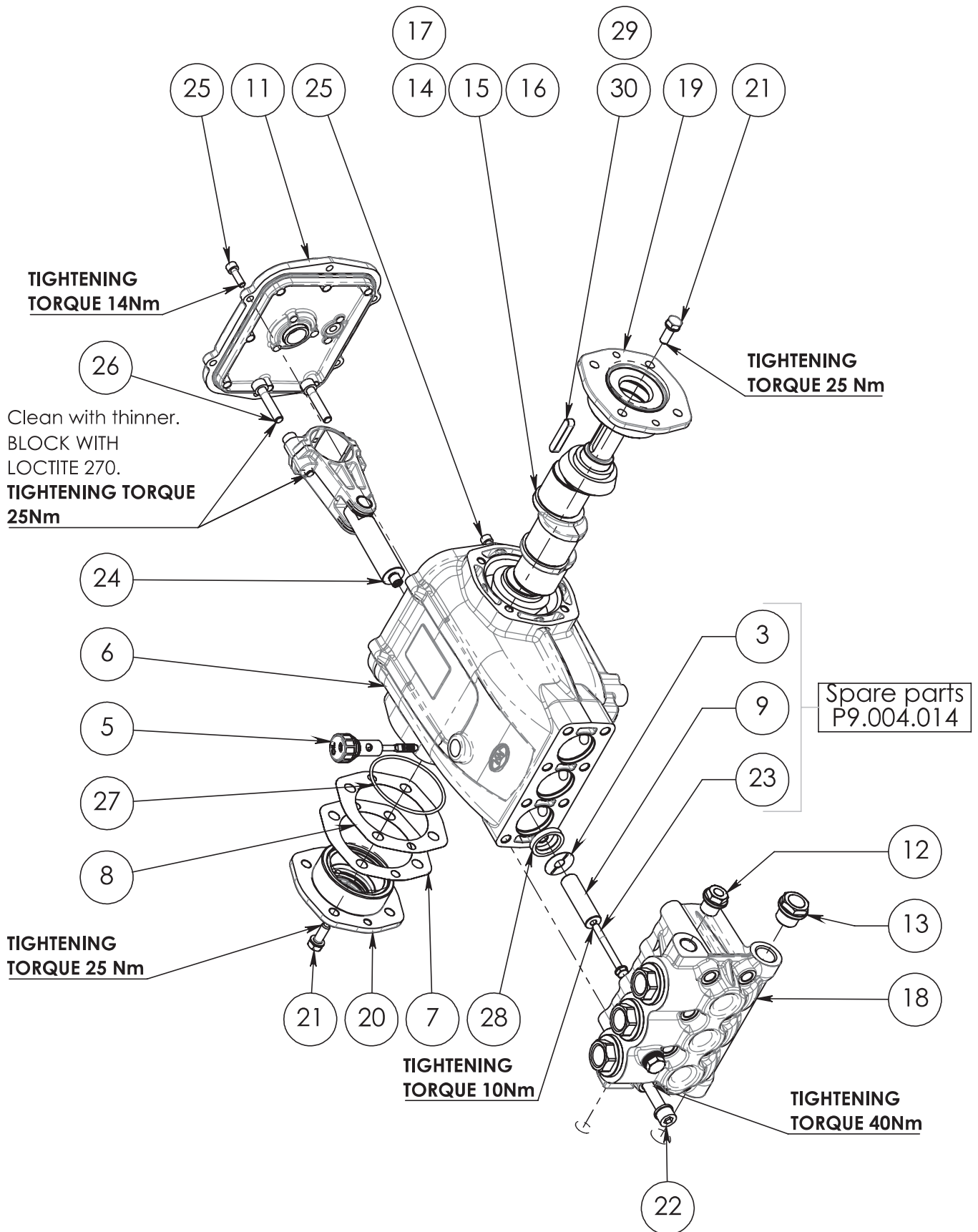



Pos.					Code	ITALIANO	ENGLISH	DEUTSCH	ESPAÑOL	FRANCAIS
	XM 11500 (R-L) Q.TY	XM 15500 (R-L) Q.TY	XM 17500 (R-L) Q.TY	XM 21500 (R-L) Q.TY						
2	1	1	1	1	P0.020.004	Olio o Lubrificante GM/XM	Oil or Lubricants GM/XM	Öl oder Schmierstoffe GM/XM	Aceite o lubrificante GM/XM	ÖlHuile ou lubrifiant GM/XM
3	3	3	3	3	P1.003.004	Rondella	Washer	Unterlegscheibe	Arandela	Rondelle
5	1	1	1	1	P2.013.035	tappo di livello con sfiato MMD-GM-XM	level cap with vent MMD-GM-XM	Level-Cap mit Lüftungs MMD-GM-XM	límite de nivel con el respiradero MMD-GM-XM	bouchon de niveau avec évent MMD-GM-XM
6	1	1	1	1	P1.020.004	Corpo Pompa GM1 XM-1	Pump Body GM1 XM-1	Pumpenkörper GM1 XM-1	Cuerpo de la bomba GM1 XM-1	Corps de pompe GM1 XM-1
7	1	1	1	1	P1.060.005	Distanziale 0,1mm	Spacer 0,1mm	Distanzstueck 0,1mm	Distanciador 0,1mm	Entretoise 0,1mm
8	1	1	1	1	P1.060.006	Distanziale sp. 0.2mm	Spacer sp. 0.2mm	Distanzstueck sp. 0.2mm	Distanciador sp. 0.2mm	Entretoise sp. 0.2mm
9	3	3	3	1	P1.071.012	Pistone Ø16 h56 XM-1	Piston Ø16 h56 XM-1	Kolben Ø16 h56 XM-1	Pistón Ø16 h56 XM-1	Piston Ø16 h56 XM-1
11	1	1	1	1	P2.012.008	Coperchio GMX	Cover GMX	Deckel GMX	Tapa GMX	Couvercle GMX
12	1	1	1	1	P2.013.029	Tappo 3/8" GAS	Cap 3/8" GAS	Deckel 3/8" GAS	Tapón 3/8" GAS	Bouchon 3/8" GAS
13	1	1	1	1	P2.013.030	Tappo 1/2" GAS	Cap 1/2" GAS	Deckel 1/2" GAS	Tapón 1/2" GAS	Bouchon 1/2" GAS
14	1	-	-	-	P2.014.006	Albero ec. 7.16	Shaft ec. 7.16	Welle ec. 7.16	Eje ec. 7.16	Arbre ec. 7.16
15	-	1	-	-	P2.014.008	Albero ec. 9.9	Shaft ec. 9.9	Welle ec. 9.9	Eje ec. 9.9	Arbre ec. 9.9
16	-	-	1	-	P2.014.009	Albero ec. 10.7	Shaft ec. 10.7	Welle ec. 10.7	Eje ec. 10.7	Arbre ec. 10.7
17	-	-	-	1	P2.014.010	Albero ec. 12.75	Shaft ec. 12.75	Welle ec. 12.75	Eje ec. 12.75	Arbre ec. 12.75
18	1	1	1	1	P2.035.020	Testata pompa XM-1	Pump head XM-1	Pumpekopf XM-1	Cabeza bomba XM-1	Tete de pompe XM-1
19	1	1	1	1	P2.060.003	Flangia P.d.F. GM-1 - XM-1	Flange P.T.O. GM-1 - XM-1	Flansch PTO GM-1 - XM-1	Brida toma de fuerza GM-1 - XM-1	Bride prise de force GM-1 - XM-1
20	1	1	1	1	P2.060.004	Flangia chiusa GM-1 - XM-1	Flange closed GM-1 - XM-1	Flansch geschlossen GM-1 - XM-1	Brida cerrada GM-1 - XM-1	Bride fermée GM-1 - XM-1
21	8	8	8	8	P2.119.002	Vite M8X22	Screw M8X22	Schrauben M8X22	Tornillo M8X22	Vis M8X22
22	8	8	8	8	P2.119.006	Vite M10X110	Screw M10X110	Schrauben M10X110	Tornillo M10X110	Vis M10X110
23	3	3	3	3	P2.119.005	Vite M6X60	Screw M6X60	Schrauben M6X60	Tornillo M6X60	Vis M6X60
24	3	3	3	3	P2.150.007	Biella GM-1 / XM-1	Connecting rod GM-1 / XM-1	Plenelstange GM-1 / XM-1	Biela GM-1 / XM-1	Bielle GM-1 / XM-1
25	6	6	6	6	P4.002.010	Vite M6x20 UNI 5931-67	Screw M6x20 UNI 5931-67	Schrauben M6x20 UNI 5931-67	Tornillo M6x20 UNI 5931-67	Vis M6x20 UNI 5931-67
26	6	6	6	6	P4.002.017	Vite TCEI M8x40 UNI5931-67	Screw TCEI M8x40 UNI5931-67	Schrauben TCEI M8x40 UNI5931-67	Tornillo TCEI M8x40 UNI5931-67	Vis TCEI M8x40 UNI5931-67
27	1	1	1	1	P4.005.016	OR 3281 ø2.62x71.12	O-ring 3281 ø2.62x71.12	O-Ring 3281 ø2.62x71.12	OR 3281 ø2.62x71.12	Joint torique 3281 ø2.62x71.12
28	3	3	3	3	P4.015.004	Anello D32-d22x5.5	Ring D32-d22x5.5	Ring D32-d22x5.5	Anillo D32-d22x5.5	Bague D32-d22x5.5
29	-	-	1	1	P4.021.002	Chiavetta 8x7x50 UNI6604-A	Key 8x7x50 UNI6604-A	Keil 8x7x50 UNI6604-A	Chaveta 8x7x50 UNI6604-A	Clavette 8x7x50 UNI6604-A
30	1	1	-	-	P4.021.003	Chiavetta 8x7x40 UNI6604-A	Key 8x7x40 UNI6604-A	Keil 8x7x40 UNI6604-A	Chaveta 8x7x40 UNI6604-A	Clavette 8x7x40 UNI6604-A

XM-1 Drawing

Disegno XM-1

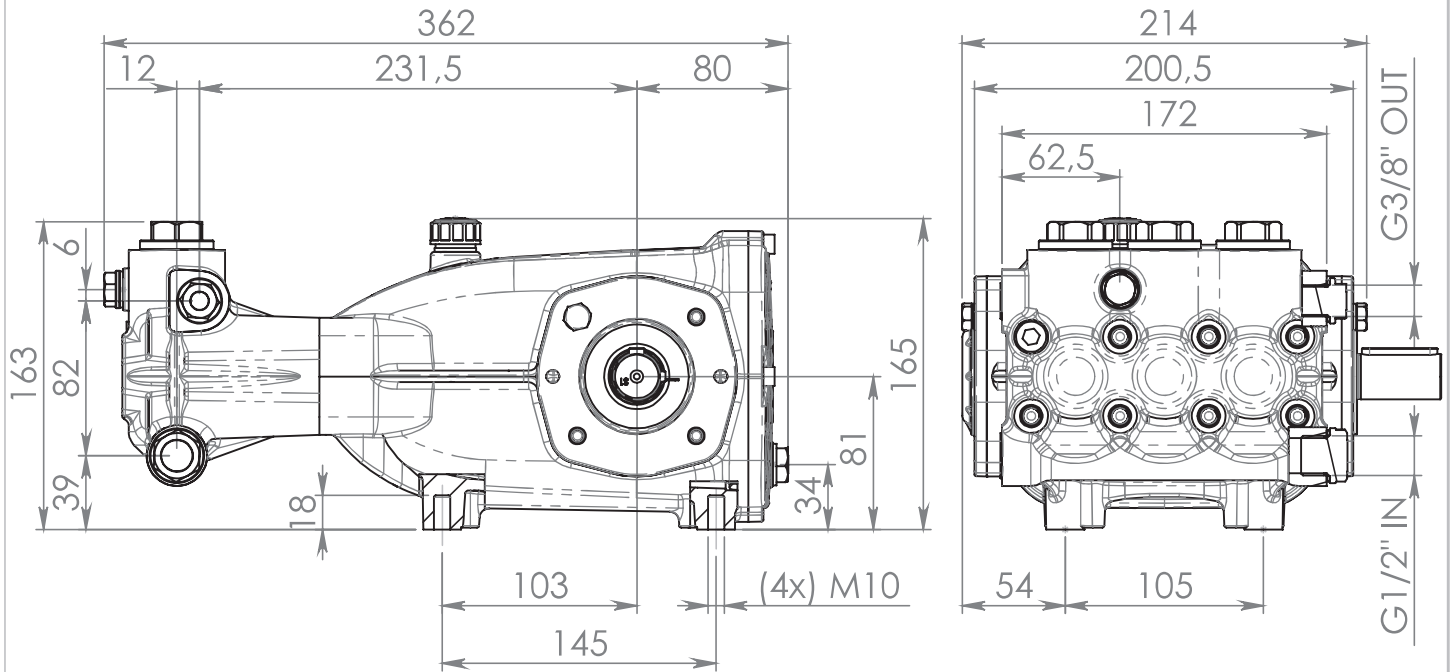

Detailed flange view

Vista dettagliata flangia

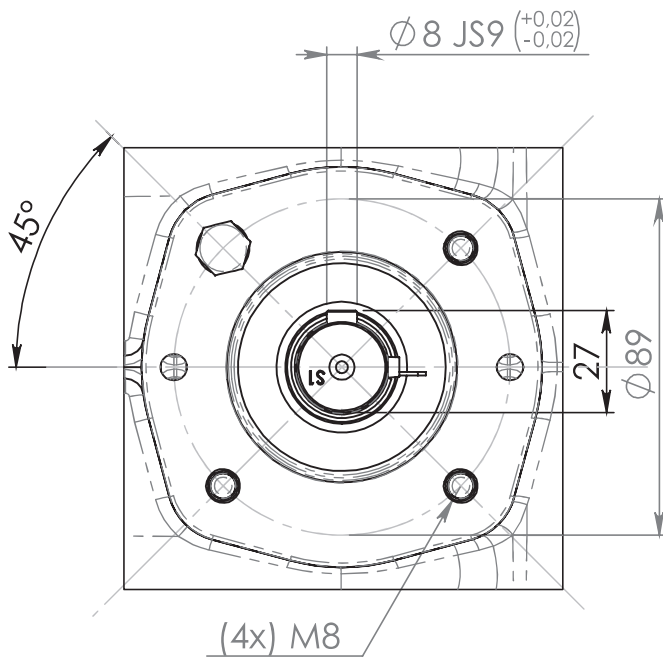

-XM 11/500
-XM 15/500

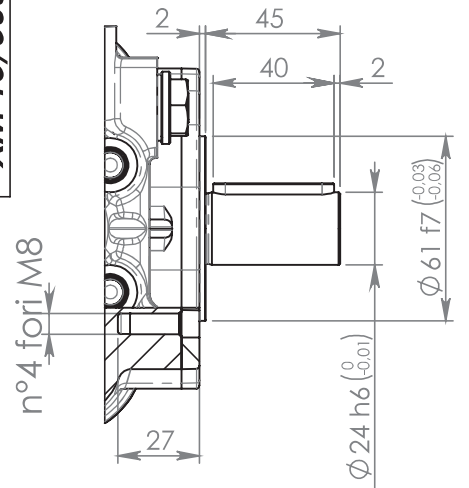

-XM 17/500
-XM 21/500

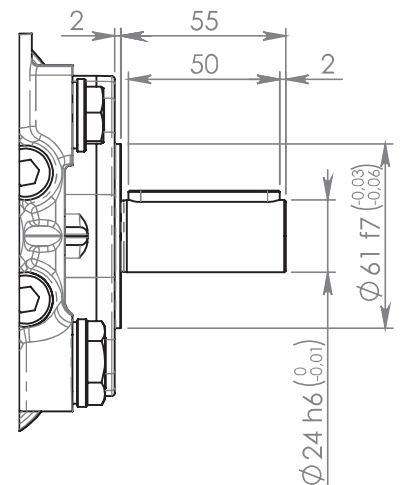

Pump head XM-1

Testata pompa XM-1



Use LOCTITE 270.
TIGHTENING TORQUE
40Nm.

Spare parts
P9.003.046

Spare parts
P9.001.004

Spare parts
P9.003.047

TIGHTENING
TORQUE 25Nm

P2.035.020.H

Spare parts P9.040.007

Pos.	Q.Ty	Code	ITALIANO	ENGLISH	DEUTSCH	ESPAÑOL	FRANCAIS
1	1	P1.012.028	Tappo G1/4	Cap G1/4	Deckel G1/4	Tapón G1/4	Bouchon G1/4
2	3	P1.024.013	Diffusore Ø16 XM-1	Diffusor Ø16 XM-1	Diffusor Ø16 XM-1	Difusor Ø16 XM-1	Diffuseur Ø16 XM-1
3	1	P1.043.013	Testata pompa XM-1	Pump head XM-1	Pumpekopf XM-1	Cabeza bomba XM-1	Tete de pompe XM-1
4	3	P2.003.009	Gruppo valvola XM-1	Valves Group XM-1	Ventil Gruppe XM-1	Groupe Vannes XM-1	Grupo Valvulas XM-1
5	3	P2.003.012	Valvola	Valve	Ventil	Válvula	Valve
6	3	P2.013.011	Tappo VAM M32	Cap VAM M32	Deckel VAM M32	Tapón VAM M32	Bouchon VAM M32
7	3	P2.118.020	Pressore XM-1	Pressure Ring XM-1	Bague de pression XM-1	Anillo de presión XM-1	Bague de pression XM-1
7.1	1	P4.100.010	Tenuta pistone posteriore Ø16xØ24x8	Piston seal back Ø16xØ24x8	Kolbendichtung zuruck Ø16xØ24x8	Piston sellado posterior Ø16xØ24x8	Piston joint arriere Ø16xØ24x8
7.2	1	P4.005.017	OR 1.78x37.82 GM-XM	O-ring 1.78x37.82 GM-XM	O-Ring 1.78x37.82 GM-XM	OR 1.78x37.82 GM-XM	Joint torique 1.78x37.82 GM-XM
8	6	P4.005.023	OR 119	O-ring 119	O-Ring 119	OR 119	Joint torique 119
9	1	P4.008.007	Rondella Rame 1/4 Ø13x19x1.5	Copper washer 1/4 Ø13x19x1.5	Kupferunterlegsscheibe 1/4 Ø13x19x1.5	Arandela de cobre 1/4 Ø13x19x1.5	Rondelle cuivre 1/4 Ø13x19x1.5
10	3	P4.100.019	Tenuta pistone anteriore Ø16xØ26x9.5	Front piston seal Ø16xØ26x9.5	Front Kolbendichtung Ø16xØ26x9.5	Junta del pistón delantero Ø16xØ26x9.5	Joint de piston avant Ø16xØ26x9.5

Connecting rod GM-1 / XM-1

Biella GM-1 / XM-1

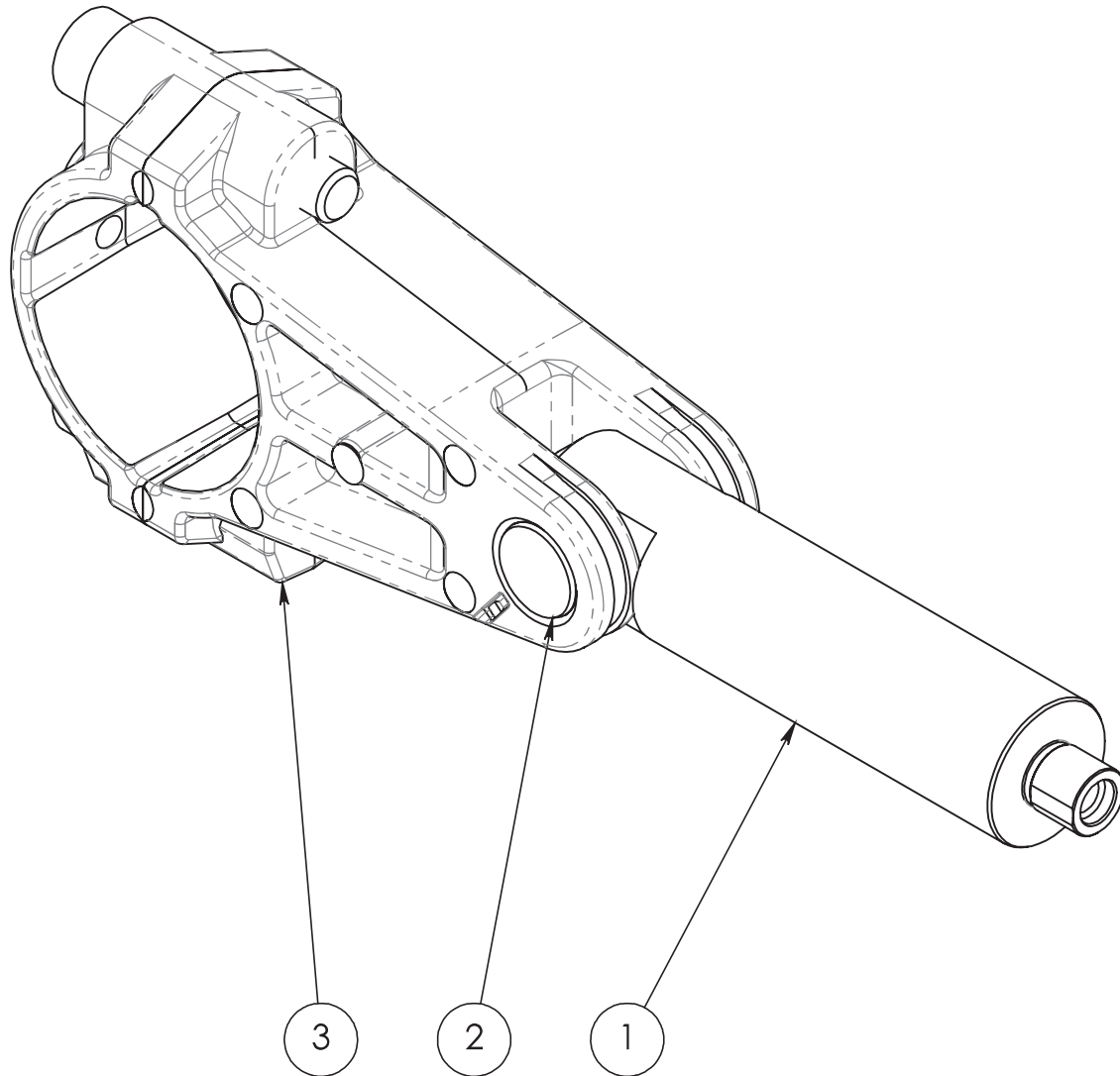

P2.150.007.A

Spare parts P9.041.005

Pos.	Q.Ty	Code	ITALIANO	ENGLISH	DEUTSCH	ESPAÑOL	FRANCAIS
1	1	P1.010.007	Asta GM-1	Pole GM-1	Pfosten GM-1	Asta GM-1	Tige GM-1
2	1	P1.013.003	Spina cilindrica	Cylindrical pin	Zylinder Stift	Pasador cilindrico	Goupille cylindrique
3	1	P1.099.007	Biella (GM-1) (XM-1)	Connecting rod (GM-1) (XM-1)	Plenelstange (GM-1) (XM-1)	Biella (GM-1) (XM-1)	Bielle (GM-1) (XM-1)

Cover GM-1/XM-1

Coperchio GM-1/XM-1

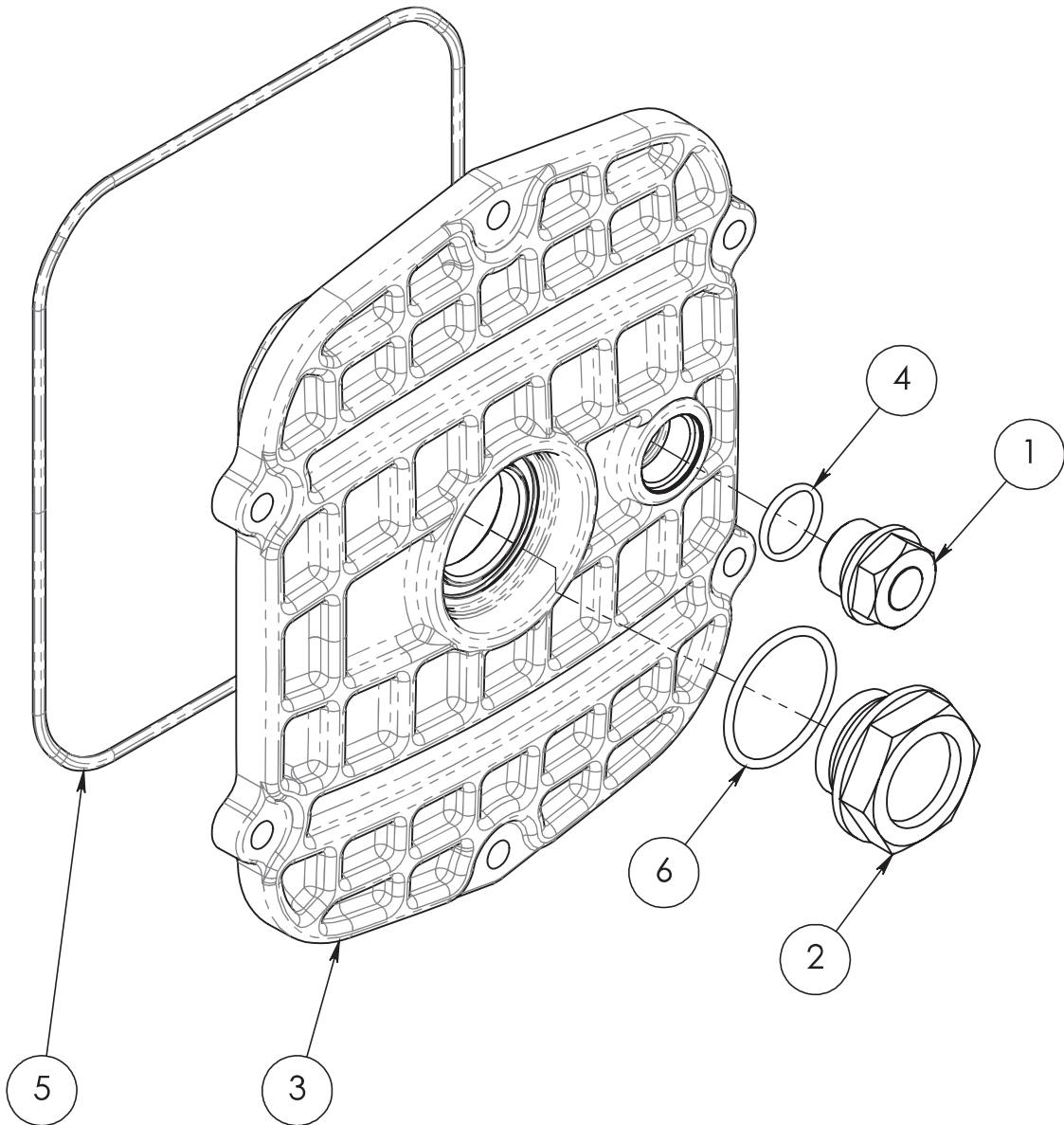

P2.012.005.E

Pos.	Q.Ty	Code	ITALIANO	ENGLISH	DEUTSCH	ESPAÑOL	FRANCAIS
1	1	P1.012.003	Tappo G 3/8" H18	Cap G 3/8" H18	Deckel G 3/8" H18	Tapón G 3/8" H18	Bouchon G 3/8" H18
2	1	P1.012.015	Tappo G3/4	Cap G3/4	Deckel G3/4	Tapón G3/4	Bouchon G3/4
3	1	P1.054.011	Coperchio	Cover	Deckel	Tapa	Couvercle
4	1	P4.005.007	Guarnizione OR 2056 14x1.78NBR 70Sh	Gasket OR 2056 14x1.78NBR 70Sh	Dichtung OR 2056 14x1.78NBR 70Sh	Guarnición OR 2056 14x1.78NBR 70Sh	Garniture OR 2056 14x1.78NBR 70Sh
5	1	P4.005.020	OR ø2.62x152.07 NBR 70sh	O-ring ø2.62x152.07 NBR 70sh	O-Ring ø2.62x152.07 NBR 70sh	OR ø2.62x152.07 NBR 70sh	Joint torique ø2.62x152.07 NBR 70sh
6	1	P4.005.030	OR ORM0285-20 (NBR)	O-ring ORM0285-20 (NBR)	O-Ring ORM0285-20 (NBR)	OR ORM0285-20 (NBR)	Joint torique ORM0285-20 (NBR)

Spare parts

Ricambi



Code	Q.Ty	ITALIANO	ENGLISH	DEUTSCH	ESPAÑOL	FRANCAIS
P2.003.009	3	Gruppo valvola XM-1	Valves Group XM-1	Ventil Gruppe XM-1	Groupe Vannes XM-1	Grupo Valvulas XM-1
P2.003.012	3	Valvola	Valve	Ventil	Válvula	Valve
P4.005.023	6	OR 119	O-ring 119	O-Ring 119	OR 119	Joint torique 119

P9.001.004
VALVOLA COMPLETA POMPA XM-1 - KIT VALVES FOR XM PUMP



Code	Q.Ty	ITALIANO	ENGLISH	DEUTSCH	ESPAÑOL	FRANCAIS
P4.005.017	3	OR 1.78x37.82 GM	O-ring 1.78x37.82 GM	O-Ring 1.78x37.82 GM	OR 1.78x37.82 GM	Joint torique 1.78x37.82 GM
P4.100.010	3	Tenuta pistone posteriore ø16xø24x8	Piston seal back ø16xø24x8	Kolbendichtung zurück ø16xø24x8	Piston sellado posterior ø16xø24x8	Piston joint arrière ø16xø24x8
P4.100.019	3	Tenuta pistone anteriore ø16xø26x9.5	Front piston seal ø16xø26x9.5	Front Kolbendichtung ø16xø26x9.5	Junta del pistón delantero ø16xø26x9.5	Joint de piston avant ø16xø26x9.5

P9.003.046
GUARNIZIONE PISTONE ø16 POMPA XM-1 - KIT PLUNGER SEALS



Code	Q.Ty	ITALIANO	ENGLISH	DEUTSCH	ESPAÑOL	FRANCAIS
P1.024.013	1	Diffusore Ø16 XM-1	Diffusor Ø16 XM-1	Diffusor Ø16 XM-1	Difusor Ø16 XM-1	Diffuseur Ø16 XM-1
P1.070.015	1	Pressore Ø16 XM-1	Pressure Ring Ø16 XM-1	Bague de pression Ø16 XM-1	Anillo de presión Ø16 XM-1	Bague de pression Ø16 XM-1
P4.005.017	1	OR 1.78x37.82 GM	O-ring 1.78x37.82 GM	O-Ring 1.78x37.82 GM	OR 1.78x37.82 GM	Joint torique 1.78x37.82 GM
P4.100.010	1	Tenuta pistone posteriore ø16xø24x8	Piston seal back ø16xø24x8	Kolbendichtung zurück ø16xø24x8	Piston sellado posterior ø16xø24x8	Piston joint arrière ø16xø24x8
P4.100.019	1	Tenuta pistone anteriore ø16xø26x9.5	Front piston seal ø16xø26x9.5	Front Kolbendichtung ø16xø26x9.5	Junta del pistón delantero ø16xø26x9.5	Joint de piston avant ø16xø26x9.5

P9.003.047
GUARNIZIONE PISTONE ø16 POMPA XM-1 PACCO COMPLETO - KIT COMPLETE SEALS



Code	Q.Ty	ITALIANO	ENGLISH	DEUTSCH	ESPAÑOL	FRANCAIS
P1.003.004	1	Rondella	Washer	Unterlegscheibe	Arandela	Rondelle
P1.071.012	1	Pistone Ø16 h56 XM-1	Piston Ø16 h56 XM-1	Kolben Ø16 h56 XM-1	Pistón Ø16 h56 XM-1	Piston Ø16 h56 XM-1
P4.002.006	1	Vite M6x60	Screw M6x60	Schrauben M6x60	Tornillo M6x60	Vis M6x60
P4.008.003	1	Rondella Rame ø6x12x1	Copper washer ø6,4x12,5x1,6	Kupferunterlegscheibe ø6,4x12,5x1,6	Arandela de cobre ø6,4x12,5x1,6	Rondelle cuivre ø6,4x12,5x1,6

P9.004.014
PISTONE Ø16 POMPA XM-1 - KIT CERAMIC PISTON



Code	Q.Ty	ITALIANO	ENGLISH	DEUTSCH	ESPAÑOL	FRANCAIS
P4.015.004	3	Anello D32-d22x5.5	Ring D32-d22x5.5	Ring D32-d22x5.5	Anillo D32-d22x5.5	Bague D32-d22x5.5

P9.039.002
ANELLI TENUTA OLIO ASTA POMPA GM-XM - KIT OIL SEALS

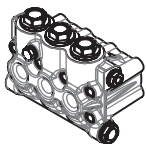

Code	Q.Ty	ITALIANO	ENGLISH	DEUTSCH	ESPAÑOL	FRANCAIS
P1.012.026	1	Tappo G3/8	Cap G3/8	Deckel G3/8	Tapón G3/8	Bouchon G3/8
P1.012.027	1	Tappo G1/2	Cap G1/2	Deckel G1/2	Tapón G1/2	Bouchon G1/2
P2.035.020	1	Testata pompa XM-1	Pump head XM-1	Pumpekopf XM-1	Cabeza bomba XM-1	Tete de pompe XM-1
P4.043.001	1	Protezione ø20	Protection ø20	Scuhtz ø20	Protección ø20	Protection ø20
P4.043.002	1	Protezione 15.5	Protection 15.5	Scuhtz 15.5	Protección 15.5	Protection 15.5

P9.040.007
TESTATA COMPLETA PISTONE ø16 POMPA XM - COMPLETE HEAD OF THE PUMP

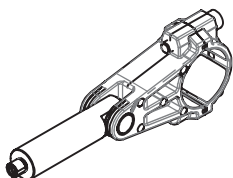

Code	Q.Ty	ITALIANO	ENGLISH	DEUTSCH	ESPAÑOL	FRANCAIS
P2.150.007	1	Biella GM-1 / XM-1	Connecting rod GM-1 / XM-1	Plenelstange GM-1 / XM-1	Biela GM-1 / XM-1	Bielle GM-1 / XM-1
P4.002.017	2	Vite TCEI M8x40 UNI5931-67	Screw TCEI M8x40 UNI5931-67	Schrauben TCEI M8x40 UNI5931-67	Tornillo TCEI M8x40 UNI5931-67	Vis TCEI M8x40 UNI5931-67

P9.041.005
BIELLA -ASTA POMPA GM-1 - XM-1 - PREASSEMBLED CONNECTING ROD

MASSIMA TEMPERATURA INGRESSO ACQUA
MAX INPUT WATER TEMPERATURE

65°C
149°F

PRESSIONE MINIMA INGRESSO
MINIMAL INPUT PRESSURE

0.2 BAR
2.9 PSI

INGRESSO
INLET

G 1/2"

USCITA
OUTLET

G 3/8"



Codice Code	Modello Model	Portata / Flow Rate lt/min - gpm		Pressione / Pressure			Potenza / Power			Albero Shaft Ø 24	mm					
		1450 rpm	1740 rpm	Bar	Psi	50Hz	HP	Kw	60Hz			HP	Kw			
		11	2,91	13,2	3,49	500,00	725,189	14,29	10,58			17,14	12,70	17,14	12,70	
P3.031.005	XM11500R	15	3,96	18	4,76	500,00	725,189	19,48	14,43	23,38	17,32	23,38	17,32	45	Destra / Right	
P3.031.006	XM15500R	17	4,49	20,4	5,39	500,00	725,189	22,08	16,35	26,49	19,62	26,49	19,62	55	Destra / Right	
P3.031.007	XM17500R	21	5,55	25,2	6,66	500,00	725,189	27,27	20,20	32,73	24,24	32,73	24,24	55	Destra / Right	
P3.031.008	XM21500R	11	2,91	13,2	3,49	500,00	725,189	14,29	10,58	17,14	12,70	17,14	12,70	45	Sinistra/Left	
P3.031.013	XM11500L	15	3,96	18	4,76	500,00	725,189	19,48	14,43	23,38	17,32	23,38	17,32	45	Sinistra/Left	
P3.031.014	XM15500L	17	4,49	20,4	5,39	500,00	725,189	22,08	16,35	26,49	19,62	26,49	19,62	55	Sinistra/Left	
P3.031.015	XM17500L	21	5,55	25,2	6,66	500,00	725,189	27,27	20,20	32,73	24,24	32,73	24,24	55	Sinistra/Left	
P3.031.016	XM21500L															

RICAMBI / SPARE PARTS

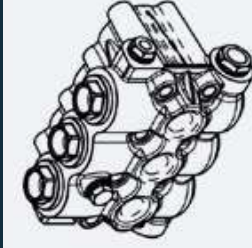

KIT - P3.040.007
TESTATA COMPLETA
COMPLETE HEAD OF THE PUMP



KIT - P3.039.002
ANELLETTINA CILINDRO
KIT OIL SEAL PUMP XM



KIT - P3.003.046
GUARNIZIONE PISTONE
KIT PLUNGER SEALS



KIT - P3.004.014
PISTONE DIAMETRO 16
KIT CERAMIC PISTON DIAMETER 16



KIT - P3.001.004
VALVOLA COMPLETA
COMPLETE VALVE



KIT - P3.003.047
GUARNIZIONE PISTONE - PACCO COMPLETO
KIT COMPLETE SEALS

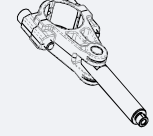

KIT - P3.041.005
PREMONTATO BIELLA-ASTA
PREASSEMBLED CONNECTING ROD

XM	PORTATA FLOW RATE		GIRI ROUNDS		PRESSIONE MASSIMA MAX PRESSURE		CAPACITÀ OLIO OIL CAPACITY		PESO WEIGHT	
	lt/min	Gpm	Rpm	Rpm	Bar	Psi	lt	Gal	kg	Lbs
50Hz	11,00 > 21,00	2,90 > 5,54	1450		500	7251.89	1,2	0,31	17	37,47
60Hz	13,20 > 25,20	3,48 > 6,65	1740							

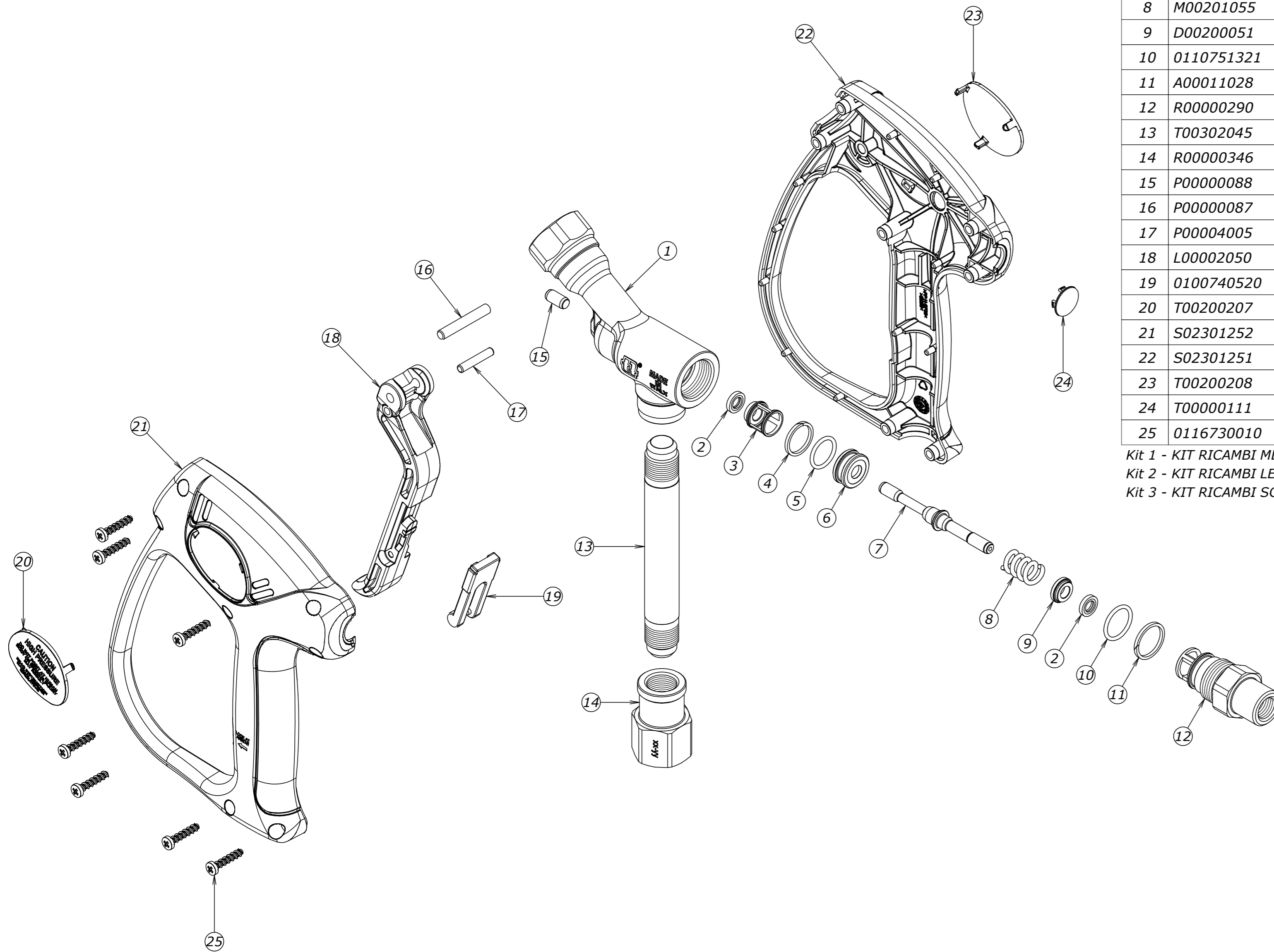

Num.	Codice	Descrizione Completa	Quant.	Kit 1	Kit 2	Kit 3
1	C00015031	CORPO ML510 NICHELATO G1/2F	1			
2	G00003003	HD SLIPPER NCR Ø6N1+N-103+OR NBR70	2	x		
3	D00200052	DISTANZIALE CONVOGLIATORE ML710	1			
4	A00011029	A.A. 15,20X18,00X1,70 TBT	1	x		
5	0110750253	GUOR 1.78X14 2056 NBR 90 NERO	1	x		
6	S00301045	SEDE ML710	1	x		
7	S02401009	STELO ML710	1	x		
8	M00201055	MOLLA 2,2X9,8X27,0	1	x		
9	D00200051	DISTANZIALE ML710	1			
10	0110751321	GUOR 1.78X15.6 2062 NBR 90 NERO	1	x		
11	A00011028	A.A. 16,70X19,50X1,70 TBT	1	x		
12	R00000290	RACCORDO ML510	1			
13	T00302045	TUBO INOX Ø17X3 L126MM G3/8	1			
14	R00000346	RACCORDO ML510 ENTRATA G 1/2 F MARC	1			
15	P00000088	PERNO Ø6X12,00 OTTONE - ML710	1		x	
16	P00000087	PERNO PER LEVA MV925 D.5X33 IX	1		x	
17	P00004005	PERNO PER LEVA MV925 D.4X22 INOX	1		x	
18	L00002050	LEVA ML710 NERA	1		x	
19	0100740520	SICURA MV951- ROSSA -	1		x	
20	T00200207	TARGHETTA ML510 SINISTRA	1			x
21	S02301252	SCOCCA ML710 SINISTRA NERA	1			x
22	S02301251	SCOCCA ML710 DESTRA NERA	1			x
23	T00200208	TARGHETTA ML510 DESTRA	1			x
24	T00000111	TAPPO SCOCHE ML510	1			x
25	0116730010	VITE AUTOF. 4 X 19 UNI 9707	7			x

Kit 1 - KIT RICAMBI ML710 - Cod. 4019900049

Kit 2 - KIT RICAMBI LEVA ML710 - Cod. 4019900050

Kit 3 - KIT RICAMBI SCOCHE ML510 - Cod. 4019900057

DENOMINAZIONE - TITLE
ML510 G 1/2 F - G 1/2 F

CODICE CLIENTE - CUSTOMER PART NO.

VIETATO RIPRODURRE O DIVULGARE IN TUTTO O IN PARTE IL PRESENTE
DISEGNO SENZA AUTORIZZAZIONE SCRITTA DELLA TECOMEC S.p.A.
IT IS FORBIDDEN TO PARTIALLY OR TOTALLY COPY, USE OR DISCLOSE THIS MATERIAL
WITHOUT PRIOR WRITTEN CONSENT FROM TECOMEC S.p.A.



42124-REGGIO EMILIA - ITALY

CODICE - PART NO.	REV.
4013300000	1

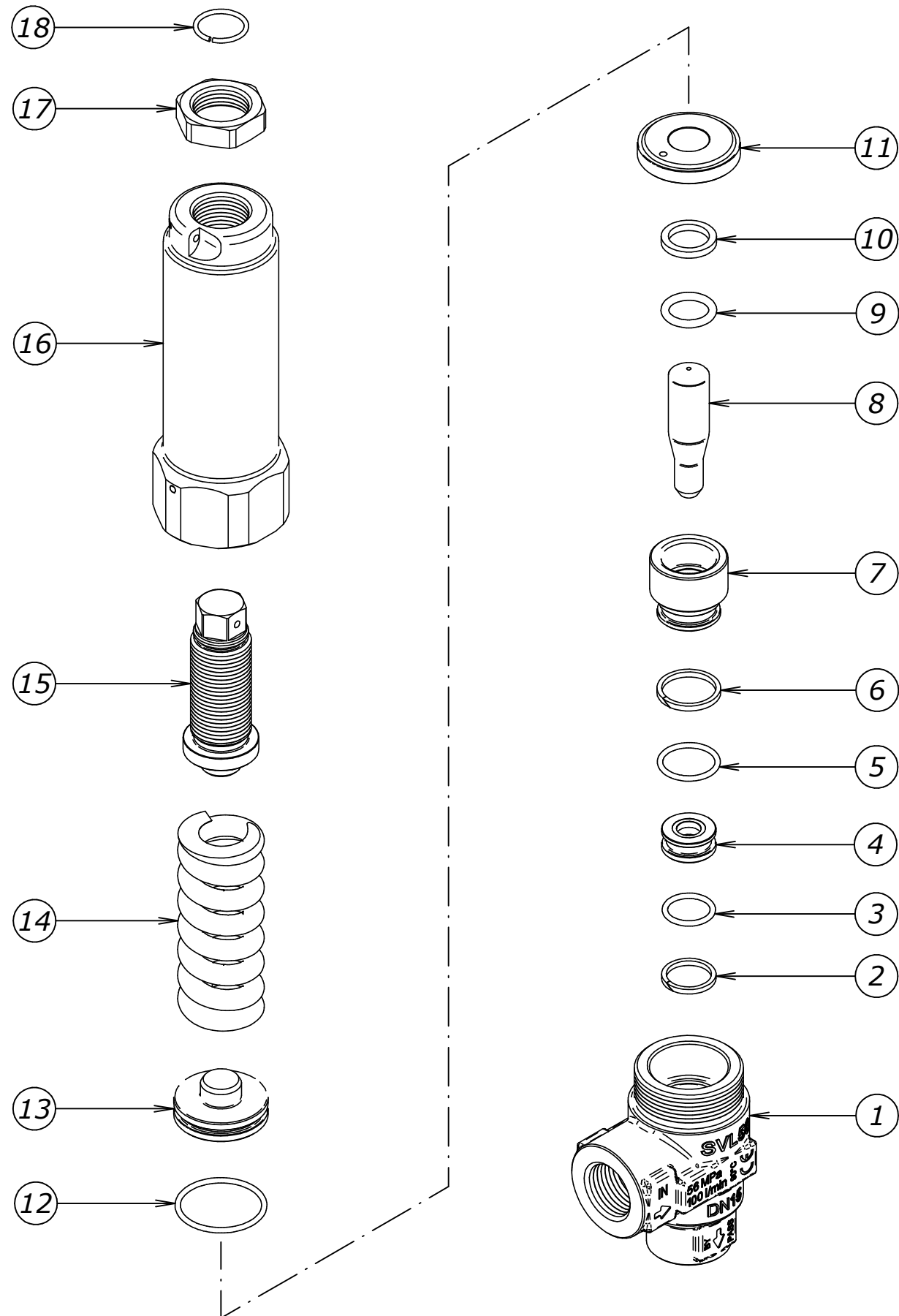

Num.	Codice	Descrizione Completa	Quant.	Kit
1	C00016034	CORPO SVL50 G1/2F - G1/2F	1	
2	A00011035	A.A. 14,9X17,9X1,8 TBT	1	X
3	0110750253	GUOR 1.78X14 2056 NBR 90 NERO	1	X
4	S00301048	SEDE SVL50	1	X
5	0110751311	GUOR 1.78X17.17 2068 NBR 90 NERO	1	X
6	A00011036	A.A. 17,9X21,0X2 TBT	1	X
7	B00400031	BOCCOLA PORTA PISTONE SVL50	1	
8	P01500010	PISTONE DI TENUTA SVL50	1	X
9	G00001250	GUOR 2.62X13.10 117 NBR 90 NERO	1	X
10	A00011037	A.A. 13,5X18,2X2,5 TB	1	X
11	B00400032	BOCCOLA GUIDA PISTONE SVL50	1	
12	G00001251	GUOR 1.78X26.7 2106 NBR 90 NERO	1	X
13	G01000009	GUIDA MOLLA SVL50	1	
14	M00202040	MOLLA 7X21,5X70 GRIGIO	1	
15	P00400023	PREMI MOLLA SVL50	1	
16	R00000270	RACCORDO PORTA MOLLA SVL50	1	
17	G00100025	GHIERA M20X1,5 ESAG.27	1	
18	A00010009	ANELLO DI FERMO SVL50	1	

KIT RIPARAZIONE (REPAIR KIT) : Cod. 4079900048

DENOMINAZIONE - TITLE SVL50 G1/2F - G1/2F		CODICE CLIENTE - CUSTOMER PART NO.	
VIETATO RIPRODURRE O DIVULGARE IN TOTO O IN PARTE IL PRESENTE DISEGNO SENZA AUTORIZZAZIONE SCRITTA DELLA TECOMECC S.p.A. IT IS FORBIDDEN TO PARTIALLY OR TOTALLY COPY, USE OR DISCLOSE THIS MATERIAL WITHOUT PRIOR WRITTEN CONSENT FROM TECOMECC S.p.A.		 CODICE - PART NO. REV. 4073500003 0	
		42124- REGGIO EMILIA - ITALY	

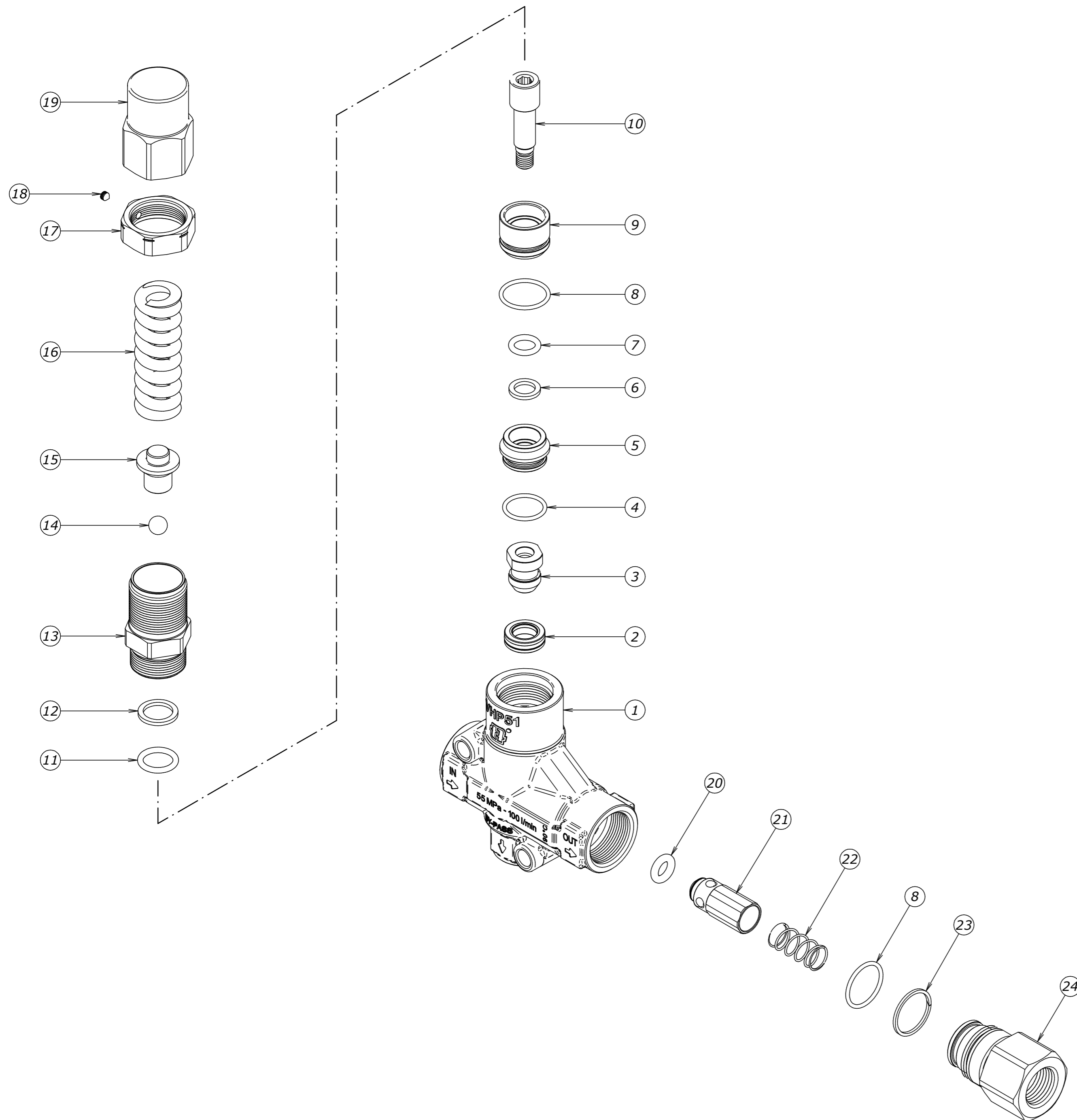

Num.	Codice	Descrizione Completa	Quant.	Kit 1
1	C00016093	CORPO NICHELATO VHP51 G1/2F	1	
2	K99900229	SEDE VHP50 CONIATA CON OR	1	x
3	O00000057	OTTURATORE DI TENUTA VHP50 - VHP60	1	x
4	0110751311	GUOR 1.78X17.17 2068 NBR 90 NERO	1	x
5	D00200053	DISTANZIALE INF. PER PISTONE VHP50	1	
6	A00011032	A.A. 10X14,7X1,8 TB	1	x
7	G00001248	GUOR 2.62X9.92 112 NBR 90 NERO	1	x
8	G00001229	GUOR 1.78X20.35 2081 NBR 90 NERO	2	x
9	D00200054	DISTANZIALE SUP. PER PISTONE VHP50	1	
10	P01500009	PISTONE VHP50	1	
11	G00001247	GUOR 2.62X13.95 3056 NBR 90 NERO	1	x
12	A00011033	A.A. 14X18,7X1,8 TB	1	x
13	R00000239	RACCORDO PISTONE VHP50	1	
14	0112720070	SFERA 11/32 AISI440 C GR10 ISO 3290	1	
15	P00000090	PERNO PORTAMOLLA VHP50	1	
16	M00202036	MOLLA 5,4X16,6X65 GRIGIO	1	
17	G00100021	GHIERA DI BLOCC. M27X1,25 - ESAG.32	1	
18	0129770060	GRANO STEI M4X4P. CON.UNI 5927 Z.B.	1	
19	M01700039	MANOPOLA DI REG. M27X1,25 ESAG. 30	1	
20	G00001231	GUOR 3.53X7.52 4028 NBR 90 NERO	1	x
21	O00000048	OTTURATORE VHP70	1	
22	M00201047	MOLLA OTTURATORE VHP70	1	
23	A00011014	A.A. 20,8X23,7X1,4 TBT	1	x
24	R00000184	RACCORDO RITEGNO G1/2F VHP70	1	

Kit 1 - KIT RICAMBIO GUARNIZIONI VHP50 - Cod. 4079900040

DENOMINAZIONE - TITLE VHP51 G1/2F		CODICE CLIENTE - CUSTOMER PART NO.	
VIETATO RIPRODURRE O DIVULGARE IN TOTO O IN PARTE IL PRESENTE DISEGNO SENZA AUTORIZZAZIONE SCRITTA DELLA TECOMECC S.r.l. IT IS FORBIDDEN TO PARTIALLY OR TOTALLY COPY, USE OR DISCLOSE THIS MATERIAL WITHOUT PRIOR WRITTEN CONSENT FROM TECOMECC S.r.l.			
		CODICE - PART NO.	REV.
		4072000122	1